



# 1.25Gb/s 1310nm Single-mode SFP Transceiver 40KM BT-SFP-IG40/BT-SFP-G40

## ❖ Overview

BT-SFP-IG40/BT-SFP-G40 Small Form Factor Pluggable (SFP) transceivers are compatible with the Small Form Factor Pluggable Multi-Sourcing Agreement (MSA). The transceiver consists of five sections: the LD driver, the limiting amplifier, the digital diagnostic monitor, the FP laser and the PIN photo-detector. The module data link up to 40KM in 9/125um single mode fiber.

The optical output can be disabled by a TTL logic high-level input of Tx Disable, and the system also can disable the module via I2C. Tx Fault is provided to indicate that degradation of the laser. Loss of signal (LOS) output is provided to indicate the loss of an input optical signal of receiver or the link status with partner. The system can also get the LOS (or Link)/Disable/Fault information via I2C register access.

## ❖ Features:

- ❖ Up to 1.25Gb/s data links
- ❖ FP laser transmitter and PIN photo-detector
- ❖ Up to 40km on 9/125µm SMF
- ❖ Hot-pluggable SFP footprint
- ❖ Duplex LC/UPC type pluggable optical interface
- ❖ Low power dissipation
- ❖ Metal enclosure, for lower EMI
- ❖ RoHS compliant and lead-free
- ❖ Single +3.3V power supply
- ❖ Support Digital Diagnostic Monitoring interface
- ❖ Compliant with SFF-8472
- ❖ Case operating temperature
  - Commercial: 0°C to +70°C
  - Industrial: -40°C to +85°C

## ❖ Applications

Switch to Switch Interface

Gigabit Ethernet

Switched Backplane Applications

Router/Server Interface

Other Optical Links



# 1.25Gb/s 1310nm Single-mode SFP Transceiver 40KM BT-SFP-IG40/BT-SFP-G40

## ❖ Absolute Maximum Ratings

Parameter	Symbol	Min.	Typ.	Max.	Unit
Storage Temperature	Ts	-40		85	°C
Relative Humidity	RH	5		95	%
Power Supply Voltage	VCC	-0.5		4	V
Signal Input Voltage		-0.3		Vcc+0.3	V
Receiver Damage Threshold		+5			dBm

## ❖ Recommended Operating Environment

Parameter	Symbol	Min.	Typ.	Max.	Unit	Note
Case Operating Temperature	Tcase	0		70	°C	BT-SFP-G40
		-40		85		BT-SFP-IG40
Power Supply Voltage	VCC	3.13	3.3	3.47	V	
Power Supply Current	ICC			280	mA	
Power Supply Noise Rejection				100	mVp-p	100Hz to 1MHz
Data Rate			1250/1250		Mbps	TX Rate/RX Rate
Transmission Distance				40	KM	
Coupled Fiber	Single mode fiber					9/125um SMF



# 1.25Gb/s 1310nm Single-mode SFP Transceiver 40KM BT-SFP-IG40/BT-SFP-G40

## ❖ Electrical Characteristics

Parameter	Symbol	Min.	Typ.	Max.	Unit	Note
<b>Transmitter</b>						
Total Supply Current	ICC			A	mA	Note (1)
Transmitter Disable Input-High	VDISH	2		V <sub>cc</sub> +0.3	V	
Transmitter Disable Input-Low	VDISL	0		0.8	V	
Transmitter Fault Input-High	VTxFH	2		V <sub>cc</sub> +0.3	V	
Transmitter Fault Input-Low	VTxFL	0		0.8	V	
<b>Receiver</b>						
Total Supply Current	ICC			B	mA	Note (1)
LOSS Output Voltage-High	VLOSH	2		V <sub>cc</sub> +0.3	V	LVTTTL
LOSS Output Voltage-Low	VLOSL	0		0.8	V	

Note (1): A (TX) + B (RX) = 280mA (Not include termination circuit)

## ❖ Specification of Transmitter

Parameter	Symbol	Min.	Typ.	Max.	Unit	Note
Average Output Power	POUT	-5		0	dBm	Note (1)
Extinction Ratio	ER	9			dB	
Center Wavelength	$\lambda_C$	1290	1310	1330	nm	FP Laser
Side Mode Suppression Ratio	SMSR	30			dB	
Spectrum Bandwidth(-20dB)	$\sigma$			1	nm	
Transmitter OFF Output Power	POff			-45	dBm	
Differential Line Input Impedance	RIN	90	100	110	Ohm	
Output Eye Mask	Compliant with IEEE802.3 z (class 1 laser safety)					Note (2)

Note (1): Measure at 2<sup>7</sup>-1 NRZ PRBS pattern

Note (2): Transmitter eye mask definition



# 1.25Gb/s 1310nm Single-mode SFP Transceiver 40KM BT-SFP-IG40/BT-SFP-G40

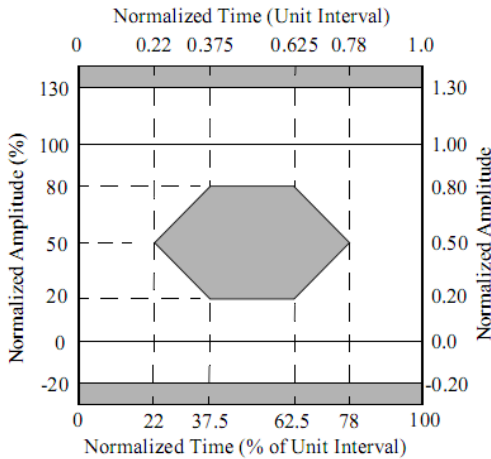

## ❖ Specification of Receiver

Parameter	Symbol	Min.	Typ.	Max.	Unit	Note
Input Optical Wavelength	$\lambda_{IN}$	1270		1610	nm	PIN-TIA
Receiver Sensitivity	PIN			-24	dBm	Note (1)
Input Saturation Power (Overload)	PSAT	-1			dBm	
Los Of Signal Assert	PA			-25	dBm	
Los Of Signal De-assert	PD	-38			dBm	Note (2)
LOS Hysteresis	PA-PD	0.5	2	6	dB	

Note (1): Measured with Light source 1310nm, ER=9dB; BER =  $<10^{-12}$  @PRBS=2<sup>7</sup>-1 NRZ.

Note (2): When LOS de-asserted, the RX data+/- output is High-level (fixed)



# 1.25Gb/s 1310nm Single-mode SFP Transceiver 40KM BT-SFP-IG40/BT-SFP-G40

## ❖ Pin Assignment:

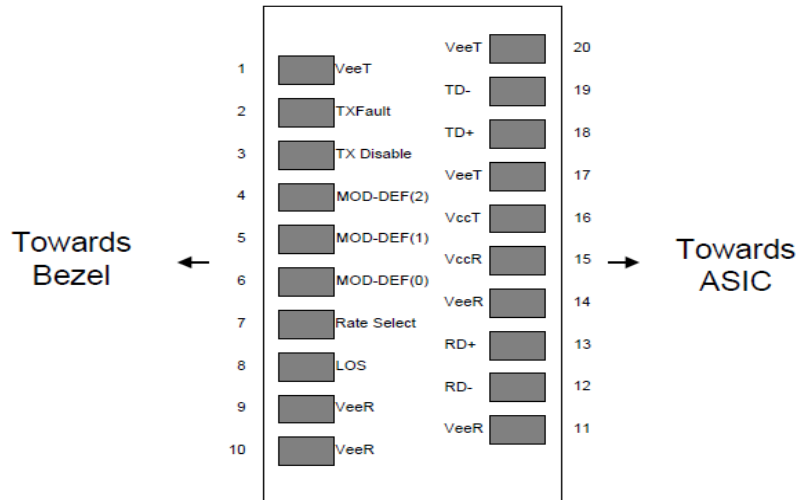

Pin out of Connector Block on Host Board



# 1.25Gb/s 1310nm Single-mode SFP Transceiver 40KM BT-SFP-IG40/BT-SFP-G40

## ❖ Pin Description:

Pin	Symbol	Name/Description	NOTE
1	VEET	Transmitter Ground (Common with Receiver Ground)	1
2	TFAULT	Transmitter Fault.	
3	TDIS	Transmitter Disable. Laser output disabled on high or open.	2
4	MOD_DEF(2)	Module Definition 2. Data line for Serial ID.	3
5	MOD_DEF(1)	Module Definition 1. Clock line for Serial ID.	3
6	MOD_DEF(0)	Module Definition 0. Grounded within the module.	3
7	Rate Select	No connection required	4
8	LOS	Loss of Signal indication. Logic 0 indicates normal operation.	5
9	VEER	Receiver Ground (Common with Transmitter Ground)	1
10	VEER	Receiver Ground (Common with Transmitter Ground)	1
11	VEER	Receiver Ground (Common with Transmitter Ground)	1
12	RD-	Receiver Inverted DATA out. AC Coupled	
13	RD+	Receiver Non-inverted DATA out. AC Coupled	
14	VEER	Receiver Ground (Common with Transmitter Ground)	1
15	VCCR	Receiver Power Supply	
16	VCCT	Transmitter Power Supply	
17	VEET	Transmitter Ground (Common with Receiver Ground)	1
18	TD+	Transmitter Non-Inverted DATA in. AC Coupled.	
19	TD-	Transmitter Inverted DATA in. AC Coupled.	
20	VEET	Transmitter Ground (Common with Receiver Ground)	1



# 1.25Gb/s 1310nm Single-mode SFP Transceiver 40KM BT-SFP-IG40/BT-SFP-G40

## Notes:

1. Circuit ground is internally isolated from chassis ground.
2. Laser output disabled on  $T_{DIS} > 2.0V$  or open, enabled on  $T_{DIS} < 0.8V$ .
3. Should be pulled up with 4.7k - 10kohms on host board to a voltage between 2.0V and 3.6V. MOD\_DEF (0) pulls line low to indicate module is plugged in.
4. This is an optional input used to control the receiver bandwidth for compatibility with multiple data rates (most likely Fiber Channel 1x and 2x Rates). If implemented, the input will be internally pulled down with  $> 30k\Omega$  resistor. The input states are:
  - Low (0 – 0.8V): Reduced Bandwidth
  - ( $> 0.8, < 2.0V$ ): Undefined
  - High (2.0 – 3.465V): Full Bandwidth
  - Open: Reduced Bandwidth
5. LOS is open collector output should be pulled up with 4.7k - 10kohms on host board to a voltage between 2.0V and 3.6V. Logic 0 indicates normal operation; logic 1 indicates loss of signal.

## ❖ Recommended Circuit

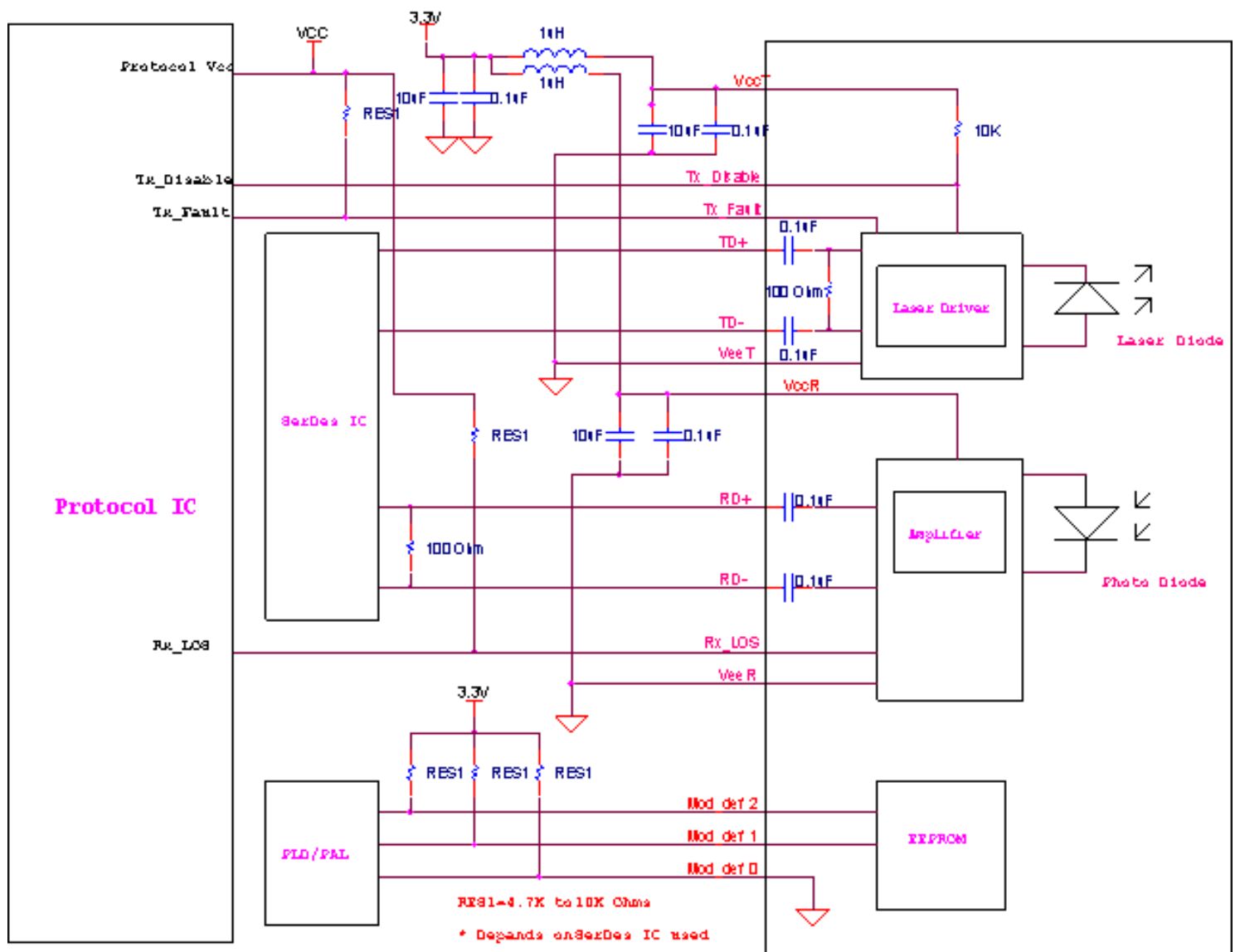





# 1.25Gb/s 1310nm Single-mode SFP Transceiver 40KM BT-SFP-IG40/BT-SFP-G40

## ❖ Digital Diagnostic Functions

BT-SFP-IG40/BT-SFP-G40 transceivers support the 2-wire serial communication protocol as defined in the SFP MSA. It is very closely related to the E2PROM defined in the GBIC standard, with the same electrical specifications.

The standard SFP serial ID provides access to identification information that describes the transceiver's capabilities, standard interfaces, manufacturer, and other information.

Additionally, BT-SFP-IG40/BT-SFP-G40 transceivers provide a unique enhanced digital diagnostic monitoring interface, which allows real-time access to device operating parameters such as transceiver temperature, laser bias current, transmitted optical power, received optical power and transceiver supply voltage. It also defines a sophisticated system of alarm and warning flags, which alerts end-users when particular operating parameters are outside of a factory set normal range.

The SFP MSA defines a 256-byte memory map in E2PROM that is accessible over a 2-wire serial interface at the 8 bit address 1010000X (A0h). The digital diagnostic monitoring interface makes use of the 8 bit address 1010001X (A2h), so the originally defined serial ID memory map remains unchanged. The interface is identical to, and is thus fully backward compatible with both the GBIC Specification and the SFP Multi Source Agreement.

The operating and diagnostics information is monitored and reported by a Digital Diagnostics Transceiver Controller (DDTC) inside the transceiver, which is accessed through a 2-wire serial interface. When the serial protocol is activated, the serial clock signal (SCL, Mod Def 1) is generated by the host. The positive edge clocks data into the SFP transceiver into those segments of the E2PROM that are not write-protected. The negative edge clocks data from the SFP transceiver. The serial data signal (SDA, Mod Def 2) is bi-directional for serial data transfer. The host uses SDA in conjunction with SCL to mark the start and end of serial protocol activation. The memories are organized as a series of 8-bit data words that can be addressed individually or sequentially.

Digital diagnostics for the BT-SFP-IG40/BT-SFP-G40 are internally calibrated by default.



# 1.25Gb/s 1310nm Single-mode SFP Transceiver 40KM BT-SFP-IG40/BT-SFP-G40

## ❖ Mechanical Specifications (Unit: mm)

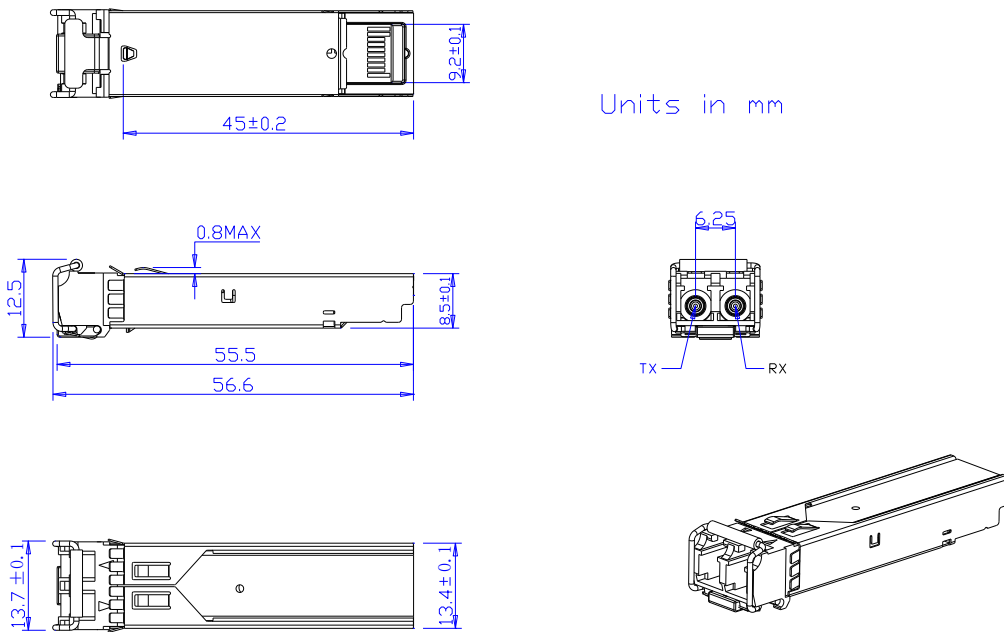

**BT-SFP-IG40/BT-SFP-G40**

## ❖ Regulatory Compliance

Feature	Reference	Performance
Electrostatic discharge (ESD)	IEC/EN 61000-4-2	Compatible with standards
Electromagnetic Interference (EMI)	FCC Part 15 Class B EN 55022 Class B (CISPR 22A)	Compatible with standards
Laser Eye Safety	FDA 21CFR 1040.10, 1040.11 IEC/EN 60825-1, 2	Class 1 laser product
Component Recognition	IEC/EN 60950 , UL	Compatible with standards
ROHS	2002/95/EC	Compatible with standards
EMC	EN61000-3	Compatible with standards



# 1.25Gb/s 1310nm Single-mode SFP Transceiver 40KM BT-SFP-IG40/BT-SFP-G40

## ❖ Ordering information

Product part Number	Data Rate (Mbps)	Media	Wavelength (nm)	Transmission Distance(km)	Temperature Range (Tcase) (°C)	
BT-SFP-G40	1250	Single mode fiber	1310	40	0~70	commercial
BT-SFP-IG40	1250	Single mode fiber	1310	40	-40~85	industrial

### BORN ELECTRONICS LIMITED

**ADDRESS:**

#94A  
Goldsmith Avenue  
London  
United Kingdom  
Phone: +4479 1989 8604  
Email: [info@bornelectronics.com](mailto:info@bornelectronics.com)

**WARRANTY:**

2 YEARS (EXPANDABLE UPTO 4 YEARS)

**WEBSITE:** <http://bornelectronics.com/>